

MDL-NS-420/1~100mW



**NANOSECOND PULSED
VIOLET DIODE LASER
AT 420nm**

This series laser products with excellent material removal rate, are widely used in microelectronics, material processing, solar energy and medical equipment manufacturing, etc.



SPECIFICATIONS

Central wavelength (nm)	420±5
Output power@3.3VDC (mW, CW)	>1, 10, 20, ...,100 (Power adjustable by software)
Power stability (rms, over 4 hours)	<3%, <2%, <1%
Pulse width (FWHM)	>10ns, 20ns, ...,10ms
Transverse mode	Near TEM ₀₀
Noise of amplitude(rms, CW)	<1%
M ² factor	<1.2
Beam diameter at the aperture (1/e ² ,mm)	~1.2
Beam divergence, full angle (mrad)	<1.0
Polarization ratio	>50:1 (>100:1, optional) Horizontal±5 degree (Vertical Optional)
User trigger frequency (Multifunctional Pulse Trigger optional)	1Hz-10MHz (1Hz-10MHz by using CNI Multifunctional Pulse Trigger)
Rise Time (ns)	<4
Fall Time (ns)	<3
Modulation Depth (extinction ratio)	>1000000:1
Warm-up time (minutes)	<5
Beam height from base plate (mm)	19
Operating temperature (°C)	10~35
Input voltage	+12VDC
Expected lifetime (hours)	10000
Warranty	1 year

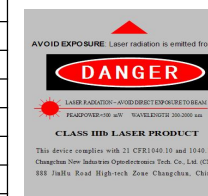

MDL-NS-420

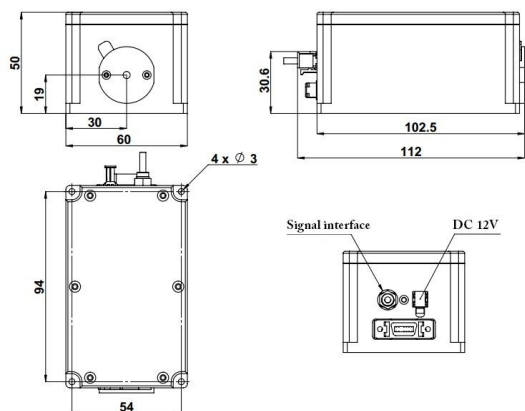

112(L) × 60(W) × 50(H) mm³, 0.5kg

Optional Power Supply

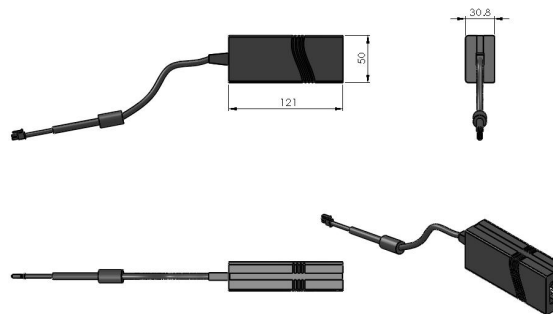

121(L) × 50(W) × 30.8 (H) mm³, 0.3kg

Multifunctional Pulse Trigger

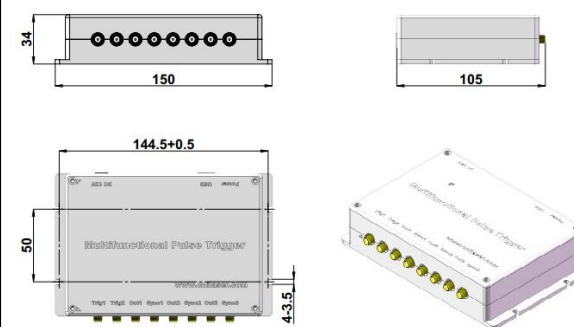

150(L) × 105(W) × 34(H) mm³, 0.5kg