

MDL-NS-642/1~80mW



NANOSECOND PULSED RED DIODE LASER AT 642nm

This series laser products with excellent material removal rate, are widely used in microelectronics, material processing, solar energy and medical equipment manufacturing, etc.



SPECIFICATIONS

Central wavelength (nm)	642±5
Output power@3.3VDC (mW, CW)	>1, 10, 20, ...,80 (Power adjustable by software)
Power stability (rms, over 4 hours)	<3%, <2%, <1%
Pulse width (FWHM)	>10ns, 20ns, ...,10ms
Transverse mode	Near TEM ₀₀
Noise of amplitude(rms, CW)	<1%
M ² factor	<1.2
Beam diameter at the aperture (1/e ² ,mm)	~1.2
Beam divergence, full angle (mrad)	<1.0
Polarization ratio	>50:1 (>100:1, optional) Horizontal±5 degree (Vertical Optional)
User trigger frequency (Multifunctional Pulse Trigger optional)	1Hz-30MHz (1Hz-25MHz by using CNI Multifunctional Pulse Trigger)
Rise Time (ns)	<3
Fall Time (ns)	<3
Modulation Depth (extinction ratio)	>1000000:1
Warm-up time (minutes)	<5
Beam height from base plate (mm)	19
Operating temperature (°C)	10~35
Input voltage	+12VDC
Expected lifetime (hours)	10000
Warranty	1 year

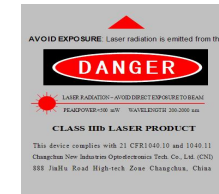

MDL-NS-642

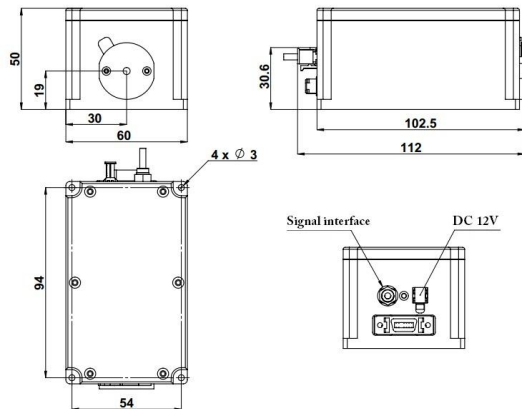

112(L) × 60(W) × 50(H) mm³, 0.5kg

Optional Power Supply

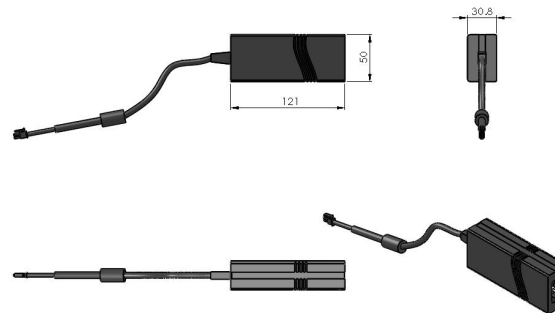

121(L) × 50(W) × 30.8 (H) mm³, 0.3kg

Multifunctional Pulse Trigger

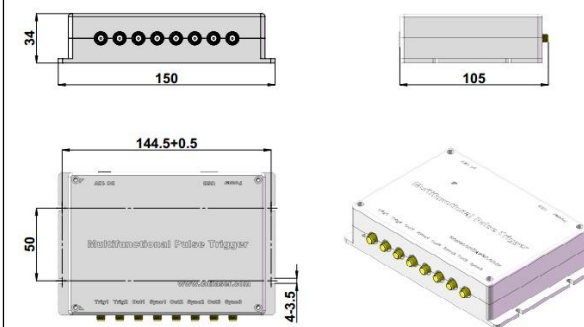

150(L) × 105(W) × 34(H) mm³, 0.5kg