



MGL-U-xxx-SF series

DPSS LASER

All solid-state CW mode laser is made features of ultra compact, easy operating, high power and stability, which is perfect for flow cytometry, spectrum analysis, microscopy, semiconductor inspection, cell sorting, optical instrument, , physics experiment, etc.



SPECIFICATIONS

Wavelength (nm)	501±1	505±1	570±2	571±1	582±2	594±1	597±1
Operating mode	CW						
Output power (mW)	1-200	1-100	1-200		1-100	50-1500	1-120
Power stability (rms, over 4 hours)	<5%, <3%						
Transverse mode	Near TEM <sub>00</sub>						
Beam diameter at the aperture (1/e <sup>2</sup> , mm)	~3		~4			<3.5	~4
Beam divergence (mrad)	<1		<3			~5	<3
Cooled method	Fan Cooled/ Water Cooled						
Warm-up time (minutes)	<10						
Beam height from base plate (mm)	91@Fan Cooled/ 55@Water Cooled						
Operating Temperature (°C)	15-30						
Power supply (90-264VAC)	PSU-W-FDA						
Expected lifetime (hours)	10000						
Warranty	1 year						



LASER HEAD (Fan Cooled)

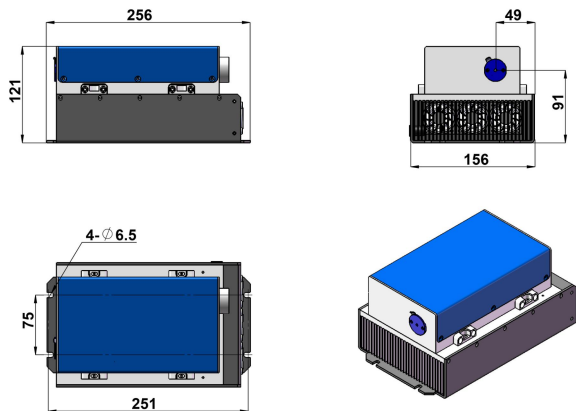

256(L)×156(W)×121(H) mm<sup>3</sup>

LASER HEAD (Water Cooled)

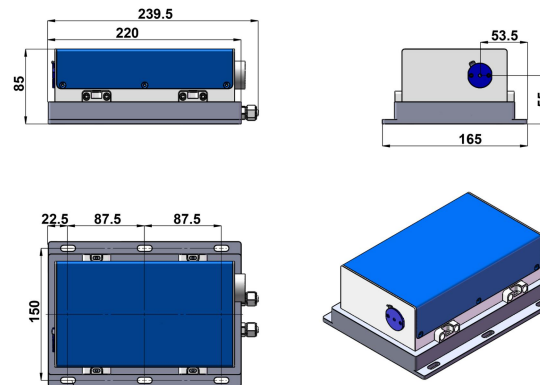

239.5(L)×165(W)×85(H) mm<sup>3</sup>

POWER SUPPLY (PSU-SF)

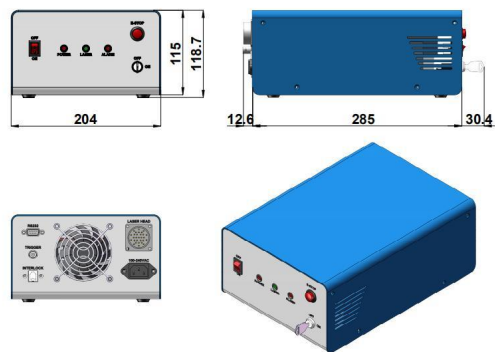

328 (L) ×204(W) ×118.7(H) mm<sup>3</sup>

WATER CHILLER



345 (L) ×248 (W) ×215(H) mm<sup>3</sup>, 10.5 kg