

MGL-W-515/150~500mW



LD PUMPED ALL-SOLID-STATE GREEN LASER

All solid state 515nm green laser is made features of ultra compact, long lifetime and easy operating, which is widely used in collimation, laser medical treatment, scientific experiment, optical instrument, laser display, laser lighting show, etc.



SPECIFICATIONS

Wavelength (nm)	515±1	
Operating mode	CW	
Output power (mW)	>150, 200, 300, ..., 500	
Power stability (rms, over 4 hours)	<5%, <3%	
Transverse mode	Near TEM ₀₀	
M ² factor	<3.0	
Beam divergence, full angle (mrad)	<2.0	
Beam diameter at the aperture (1/e ² , mm)	~3.0	
Warm-up time (minutes)	<10	
Polarization ratio	>100:1	
Beam height from base plate (mm)	93.5	
Operating temperature (°C)	10~35	
Power supply (90-264VAC)	PSU-W-LED	PSU-W-FDA
TTL / Analog modulation	TTL or Analog with 1Hz-1kHz 1kHz-10kHz, 10kHz-30kHz optional	
Expected lifetime (hours)	10000	
Warranty period	1 year	

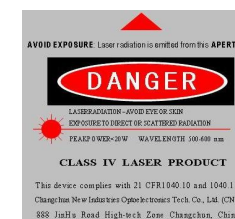

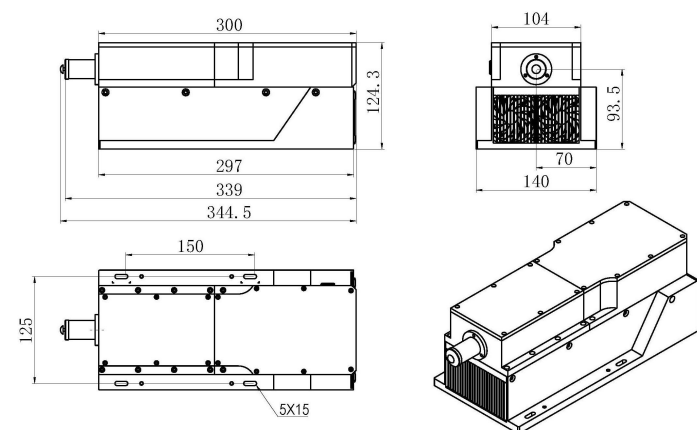
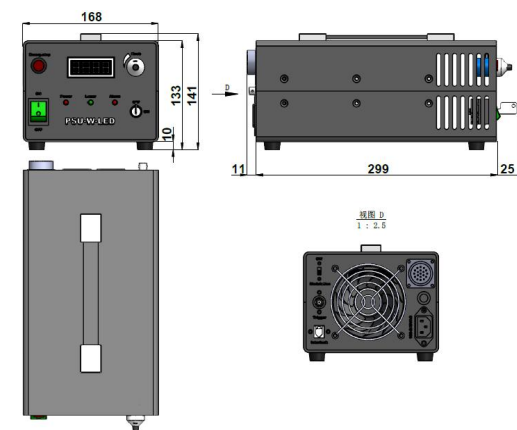
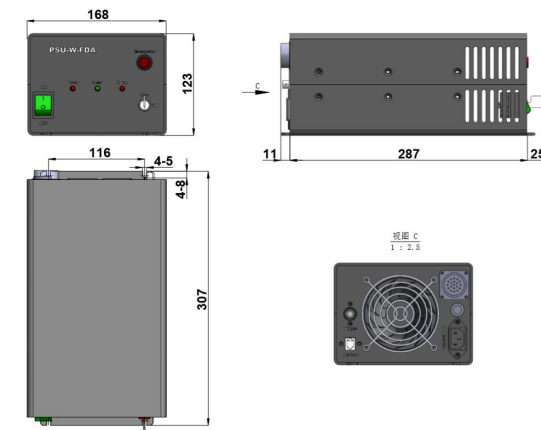
MGL-W-515	PSU-W-LED	PSU-W-FDA
 <p>344.5 (L) × 140 (W) × 124.3 (H) mm³, 5.7 kg</p>	 <p>335 (L) × 168 (W) × 141 (H) mm³, 4.2 kg</p>	 <p>323 (L) × 168 (W) × 123 (H) mm³, 4.1 kg</p>