

MPL-F-349/0.1~10uJ/1~30mW



LD PUMPED ALL-SOLID-STATE  
UV LASER

All solid state 349 nm UV laser is made features of ultra compact, long lifetime, low cost and easy operating, which is widely used in UV curing, micro-electronics, CD carving, laser medical treatment, scientific experiment, etc.



SPECIFICATIONS

Central wavelength (nm)	349±1	
Output average power (mW)	1~30	
Transverse mode	Near TEM <sub>00</sub>	
Operating mode	Frequency conversion of Q-switched pulsed laser	
Single pulse energy (μJ)	0.1~10	
Pulse duration (ns)	~4	
Peak power(W)	25~2500	
Rep. rate (kHz)	Controllable	Specified One rep. rate, such as 0.1Hz, 100 Hz, 500 Hz up to 1kHz, with stable laser pulses emitting (stable pulse energy, peak, duration and period). Different rep. rate in the range of 0.1Hz to 1kHz can be obtained by input an external TTL signal.
	Uncontrollable	QCW state with one rep. rate between 2kHz-3kHz.
Average power (mW)	Average power (mW) = Single pulse energy (μJ) * Rep. rate (kHz)	
Ave power stability (over 4 hours)	<5%, <10%	
Beam divergence, full angle (mrad)	<1.5	
Beam diameter at the aperture (mm)	~2.0	
Polarization ratio	>50:1	
Pointing stability after warm-up (mrad)	<0.05	
Warm-up time(minutes)	<10	
Beam height from base plate (mm)	45	
Operating temperature (°C)	10~35	
Spectral purity	>99%	
Power supply (90-264VAC)	PSU-H-FDA	
Expected lifetime (hours)	5000	
Warranty period	1 year	
Remarks	Please Note: because of the Walk-off effect of Nonlinear crystals, the beam quality of UV laser is not so good as that of 1047/523nm laser.	



MPL-F-349

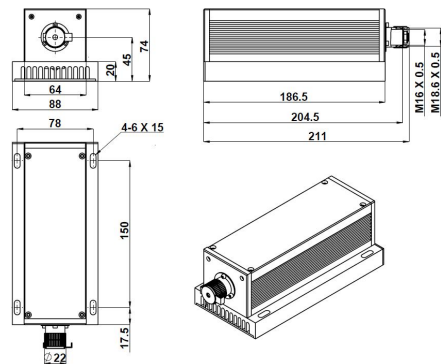

211 (L)×88(W)×74(H) mm<sup>3</sup>, 1.6 kg

PSU-H-FDA

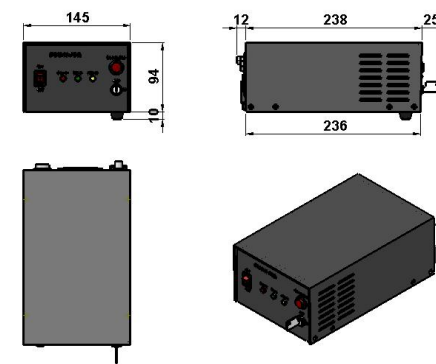

275(L)×145(W)×104(H) mm<sup>3</sup>, 2.3 kg