



MSL-III-xxx-AOM series

HIGH FREQUENCY MODULATED SINGLE LONGITUDINAL MODE GREEN LASER

High frequency modulated laser system has such characteristics as quick modulation rate, high extinction ratio, easy coding and convenient use. Laser modulation frequency of this laser system can be up to 1MHz, It is mainly used in such fields as laser text-image processing , laser lithography, laser Phototypesetting, and laser digital communication. It is suitable for OEM system integration and scientific research laboratories etc.



SPECIFICATIONS

Wavelength (nm)	532±1
Operating mode	CW
Output power (mW)	1-30
Power stability (rms over 4 hours)	<3%, <2%, <1%
Transverse mode	Near TEM ₀₀
Longitudinal mode	Single
Spectral line width (nm)	<0.00001
Coherent length (m)	>50
Optical Noise (rms,20~20MHz)	<0.5%
M ² factor	<1.3
Beam diameter at the aperture (1/e ² , mm)	<1.5
Beam divergence, full angle (mrad)	<1.2
Warm-up Time (minutes)	<5
Beam height from base plate (mm)	24.8
Operating temperature (°C)	10-35
Power supply (90-264VAC)	PSU-III-FDA-AOM
Modulation	1MHz
Expected lifetime (hours)	10000
Warranty	1 year



LASER HEAD

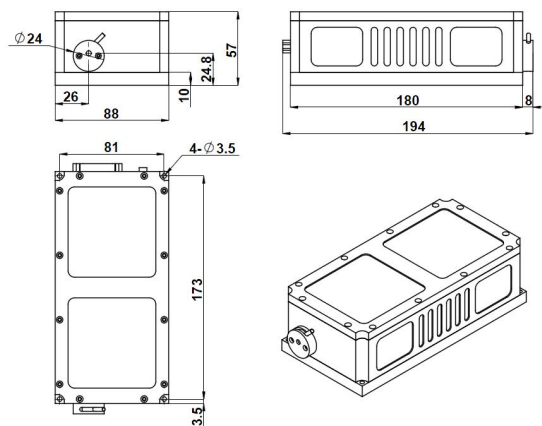

194(L)×88(W)×57(H) mm³, 1.6kg

POWER SUPPLY

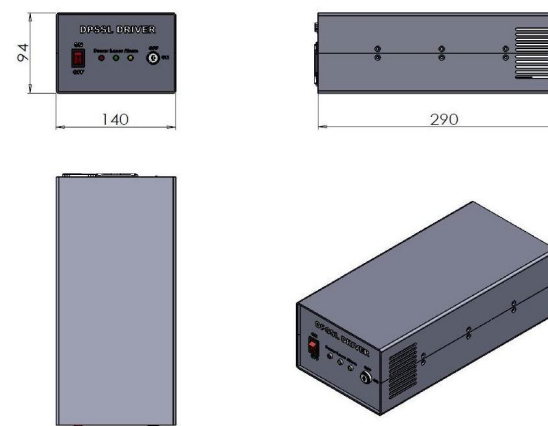

290 (L) ×140(W) ×94 (H) mm³, 2.3 kg