

PGL-D12-405

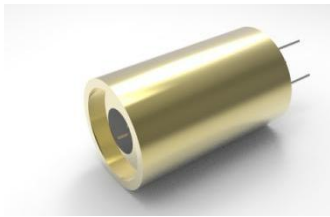

PGL-D12 high power blue laser module at 405nm is made features of small size, high output power, long lifetime, which made it be used widely in collimation, laser medical treatment, scientific experiment, optical instrument and so on.

SYSTEM SPECIFICATIONS*

Wavelength	nm	405
Wavelength tolerance	nm	±10
Output power	mW	1-100
Operating mode		CW
Transverse mode		Near TEM ₀₀
Beam diameter at the aperture(1/e ²)	mm	~3.5
Beam divergence, full angle	mrad	<0.5
Expected lifetime	hours	10000
Warranty	years	1

ELECTRICAL SPECIFICATIONS

Operating voltage(external PCB1)	6VDC(TTL10kHz, optional)
Operating voltage(external PCB2)	5VDC(TTL30kHz or Analog0-3V,0-5V, optional)
Operating voltage(external PCB3)	5-12VDC(TTL30kHz and Analog 0-3V,0-5V, optional)
Connection	Cable with flying leads

ENVIRONMENTAL CONDITIONS

Operating temperature	0°C to 40°C
Storage temperature	-20°C to 80°C
Humidity	<90 %, non-condensing
Dissipated heat	<1.8W

MECHANICAL SPECIFICATIONS

Laser head diameter Φ	mm	12
Length	mm	20
Material		Copper
Shell polarity		The housing is isolated.

*All testing data under the conditions of temperature 25°C.

Dimensions of laser($\Phi 12 \times 20 \text{mm}^2$)

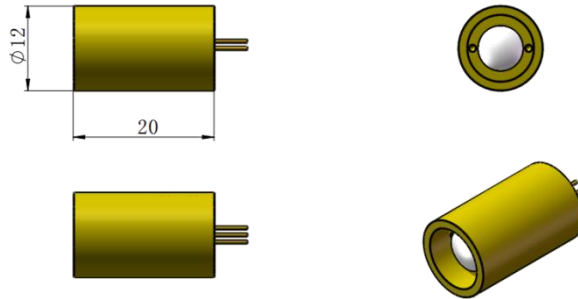

Dimensions of PCB1(*small size*, $9 \times 12 \text{mm}^2$, 6VDC, TTL)

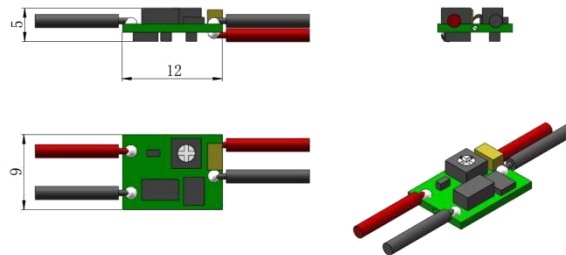

Dimensions of PCB2($11 \times 25 \text{mm}^2$, 5VDC, TTL or Analog)

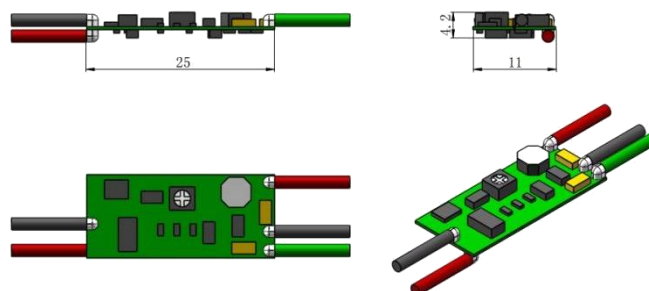

Dimensions of PCB3(*wide voltage input range*, $20 \times 30 \text{mm}^2$, 5-12VDC, TTL and Analog)

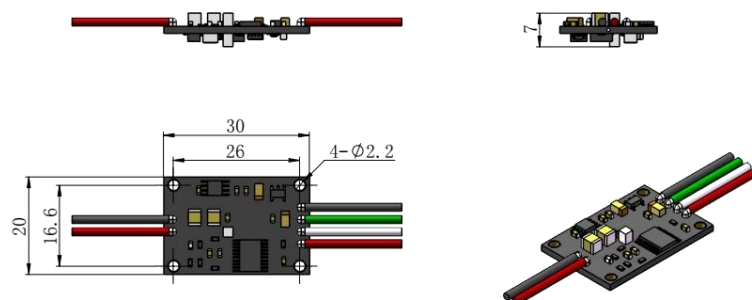

AD-6V 1A POWER ADAPTER

Input 100-240VAC 50-60Hz

Output DC 6V 1A

Dimensions of power adapter (mm):

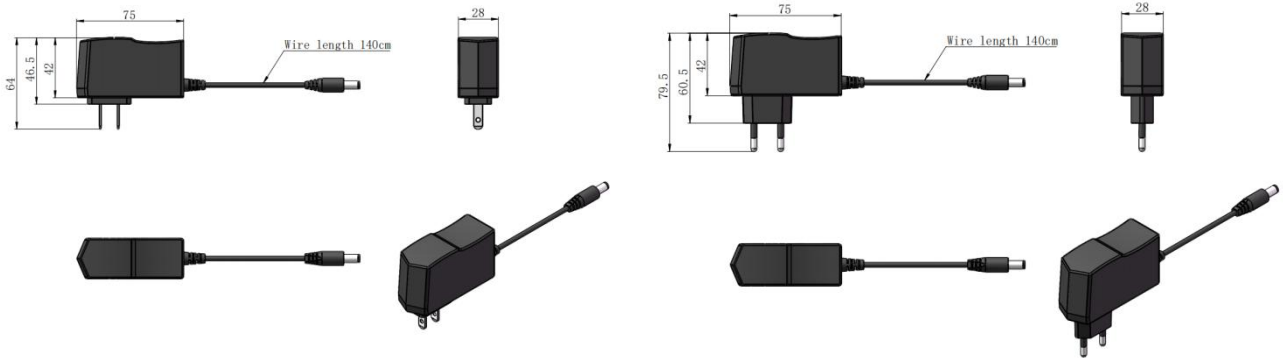

AD-5V 5A POWER ADAPTER

Input 85-264VAC 47/63Hz

Output DC 5V 5A

Dimensions of power adapter (mm):

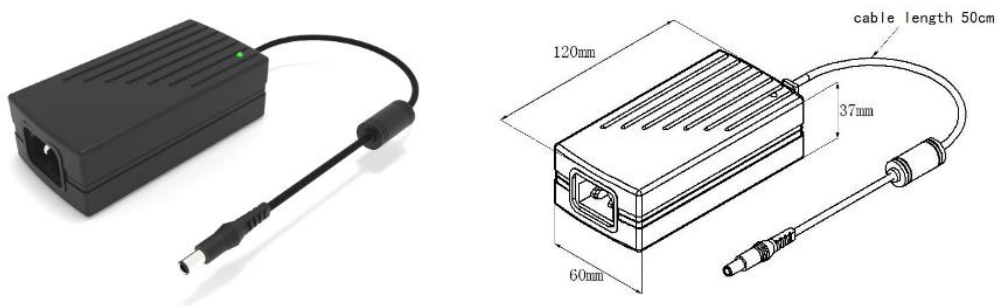

AD-12V 3.34A POWER ADAPTER

Input 100-240VAC 50/60Hz

Output DC 12V 3.34A

Dimensions of power adapter (mm):

