

DPS-532-BS-D/15~50mJ

**HIGH ENERGY DIODE
PUMPED ALL-SOLID-STATE
Q-SWITCHED LASER**

High energy diode pumped all solid state Q-switched laser at 532nm has the features of high single pulse energy, short pulse duration, and high peak power, which is widely used in LIBS, LIF, ICP-MS, LCD repair, scientific research, and so on.



SPECIFICATIONS

Wavelength (nm)	532±1			
Operating mode	Q-switched: EO (Electro-optic)			
Single pulse energy (mJ)	15	25	40	50
Pulse duration (ns)	<10			
Rep. rate (Hz)	1~20, EXT (adjustable)			
Energy stability (std dev/mean)	<5%, <3%			
Beam divergence, full angle (mrad)	≤3			
Beam diameter (mm)	~5			
Warm-up time (minutes)	<15			
Beam height from base plate (mm)	53			
Cooled method	Air cooled			
Operating temperature (°C)	15~30			
Power supply	PSU-DPS-BS-D			
Expected lifetime (pulses)	10 ⁹			
Warranty period	1 year			

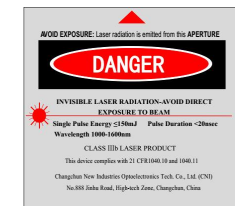

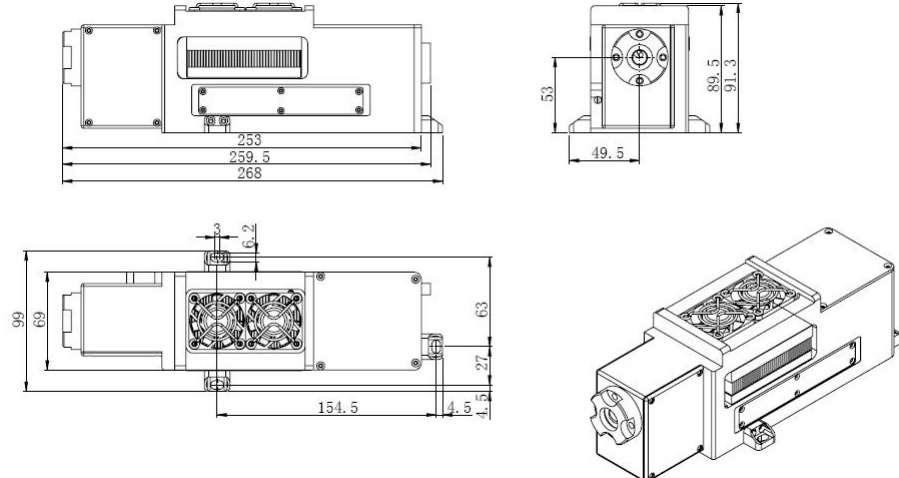
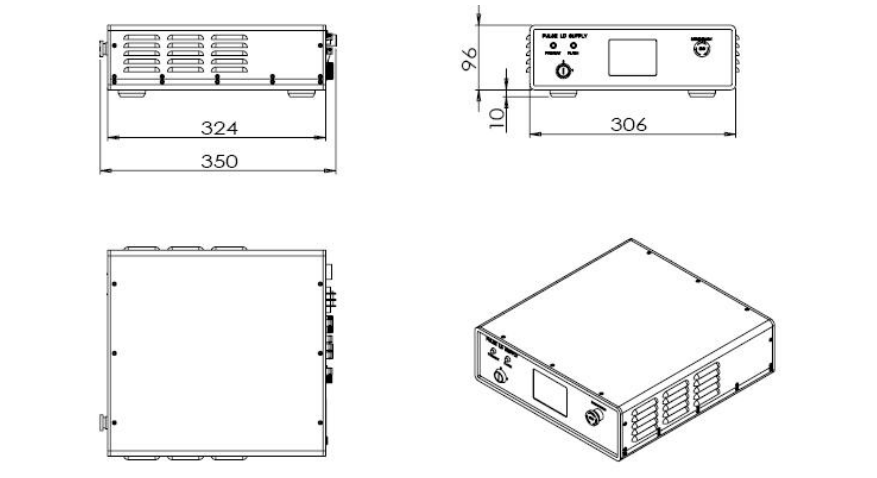
DPS-532-BS-D	PSU-DPS-BS-D
 <p>268(L)×99(W)×91.3(H)mm³, 2.5kg</p>	 <p>350(L)×306(W)×106(H) mm³, 6kg</p>