

FS-F-515-2 μ J/2W

**FEMTOSECOND PULSED
LASER AT 515nm**

Femtosecond pulsed laser at 515nm is made features of short pulse duration, high repetition rate, high stability and good beam quality, which is used in sapphire marking, ceramic cutting, semiconductor cutting, film scribing, physics experiment, etc.



SPECIFICATIONS

Wavelength (nm)	515 \pm 5
Average power (W)	2W (2W@1MHz)
Single pulse energy (μ J)	2(2 μ J @1MHz)
Rep. rate (MHz)	1MHz
Pulse duration (fs)	<350fs @1MHz,2W.
Peak power (MW)	5.7MW @1MHz
Ave power stability (over 4 hours)	<1%
Warm-up time (minutes)	<10
Transverse mode	TEM ₀₀
Beam quality(M ²)	<1.3
Beam divergence, full angle (mrad)	<1.0
Beam diameter at the aperture (1/e ² ,mm)	~2
Polarization ratio	>100:1
Beam height from base plate (mm)	178
Cooled method	Air cooled

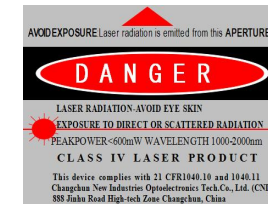

FS-F-515

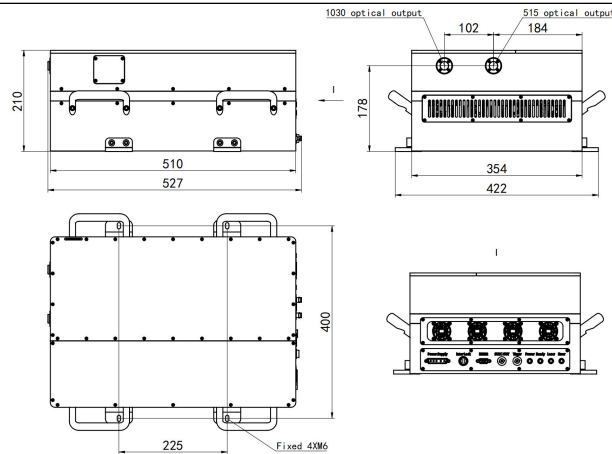

510(L) × 354(W) × 210(H) mm³, 40 kg

Power supply

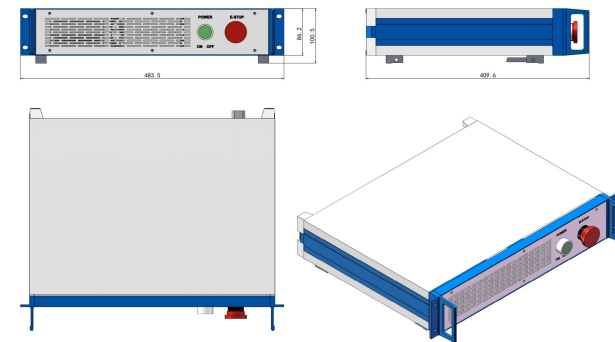

483.5 (L) × 409.6(W) × 100.5(H) mm³, 4.5 kg