



中国长春新产业光电技术有限公司  
Changchun New Industries Optoelectronics Tech. Co., Ltd

## PGL-FS-520



Green laser module at 520nm is made features of ultra compact, long lifetime and easy operating, which made it be used widely in laser projection, laser show, biomedical applications, holography, metrology, etc.

### SYSTEM SPECIFICATIONS\*

Wavelength	nm	520
Wavelength tolerance	nm	±10
Output power	mW	1-100
Power stability(rms, over 4 hours)		<5%, <3%, <1%
Operating mode		CW
Transverse mode		Near TEM <sub>00</sub>
Beam diameter at the aperture(1/e <sup>2</sup> )	mm	~4.5
Beam divergence, full angle	mrad	<1
Warm-up time	minutes	<10
Beam height from base plate	mm	15
Expected lifetime	hours	10000
Warranty	years	1

### ELECTRICAL SPECIFICATIONS

Operating voltage(PSU-V-OEM)	100-240VAC
Operating voltage(PSU-I-OEM)	12VDC
Modulation optional	TTL30kHz and Analog 0-5V
Connection	9 pin connector

### ENVIRONMENTAL CONDITIONS

Operating temperature	-10°C to 50°C
Storage temperature	-20°C to 80°C
Humidity	< 90%, non-condensing

### MECHANICAL SPECIFICATIONS

Dimensions of laser head	77(L)×30(W)×30(H)mm <sup>3</sup>
Material	Aluminum

\*All testing data under the conditions of temperature 25°C.

Dimensions of laser head(77×30×30mm<sup>3</sup>)

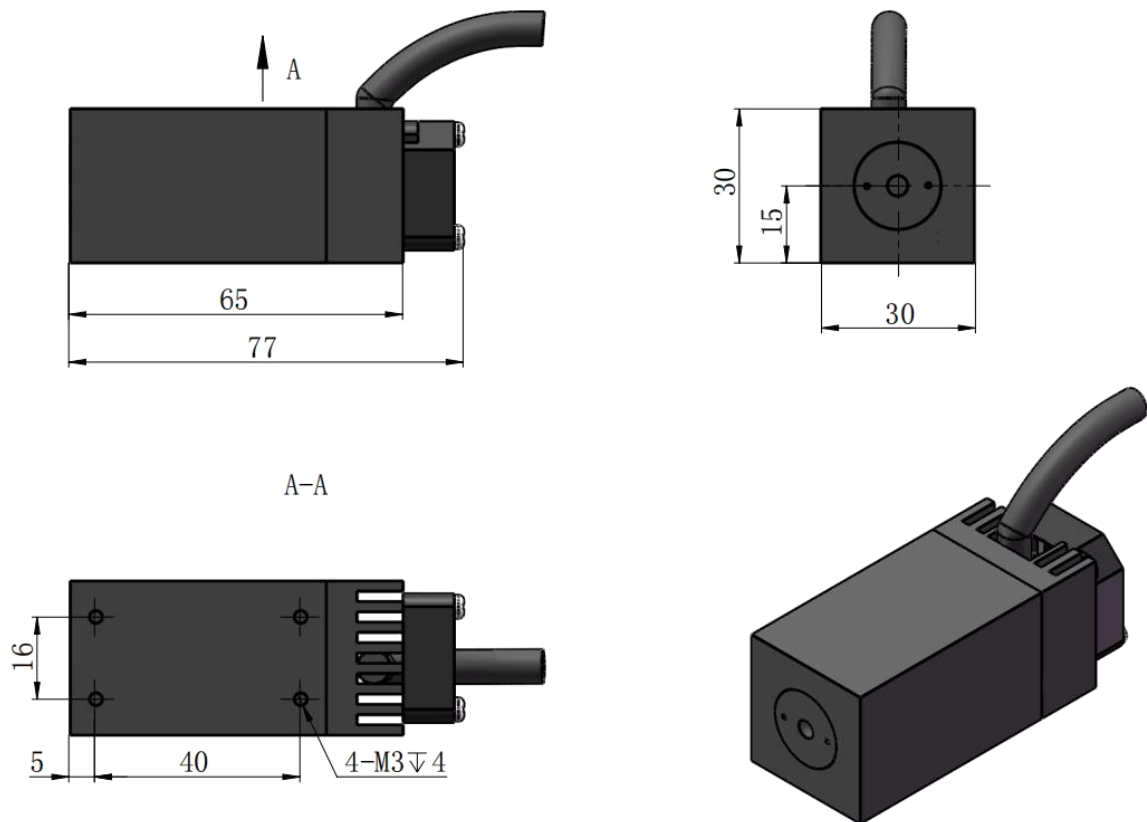

Dimensions of PSU-V-OEM power supply  
(107×47×39mm<sup>3</sup>, 100-240VAC, TTL 30kHz and Analog 0-5V)

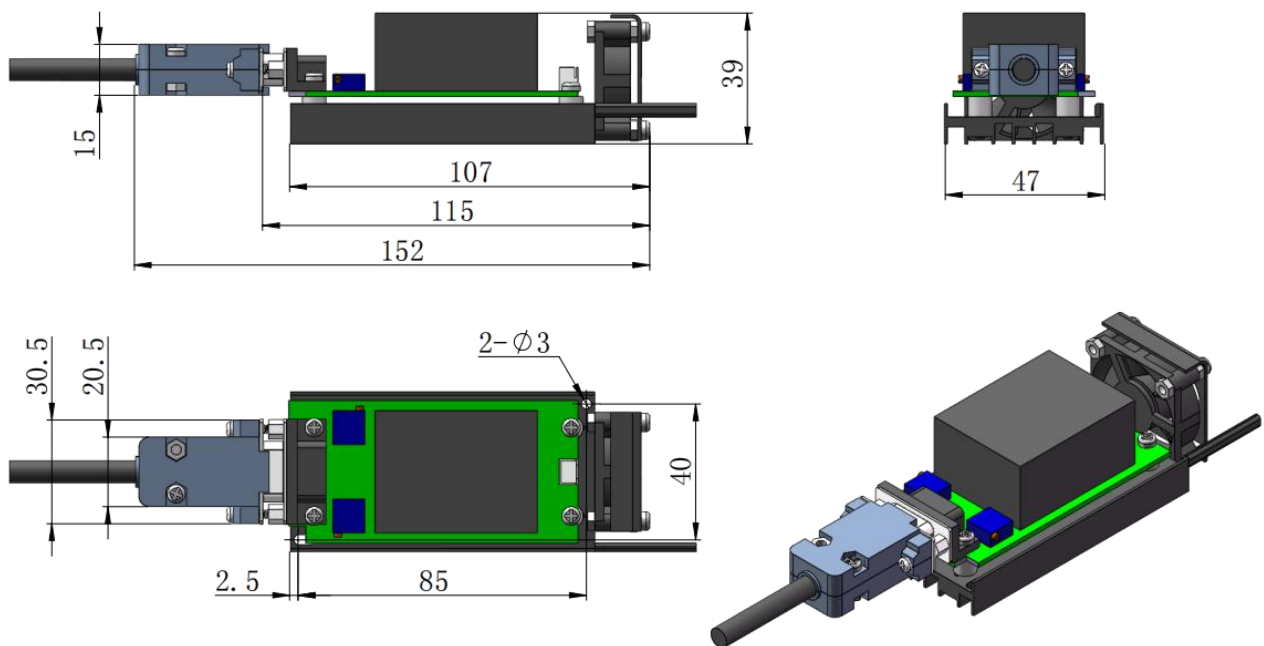

Dimensions of PSU-I-OEM power supply(107×47×38mm<sup>3</sup>, 12VDC, TTL 30kHz and Analog 0-5V)

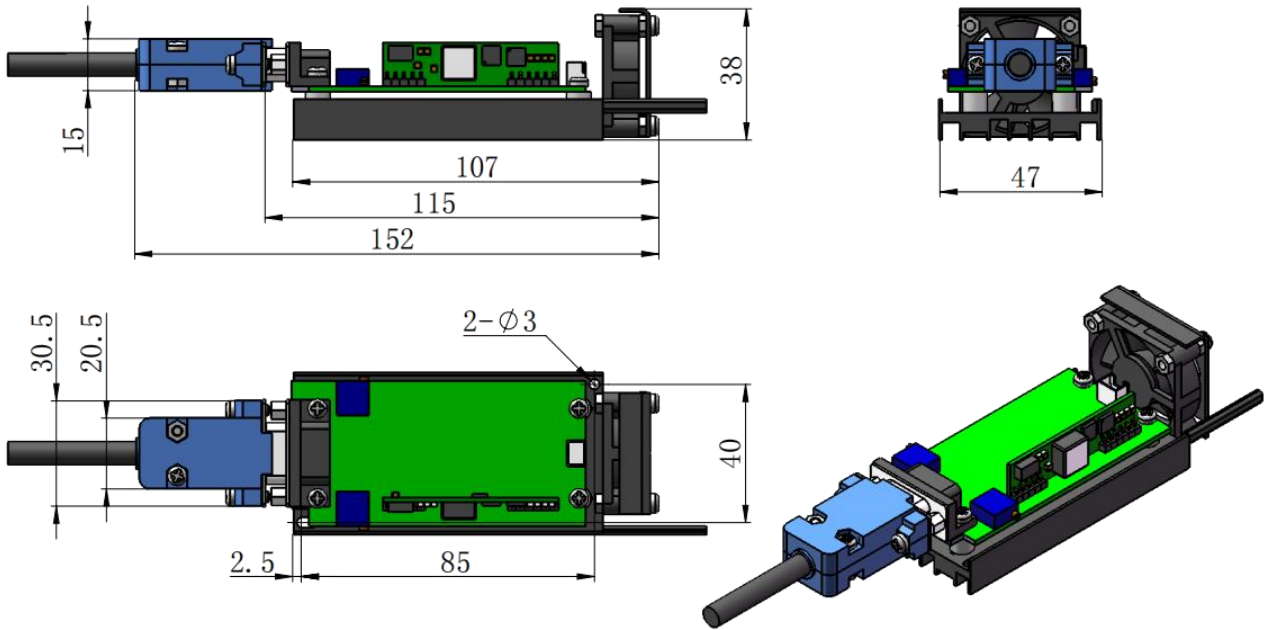

Dimensions of PSU-V-OEM and PSU-I-OEM power supply with dust cover(110×70×47mm<sup>3</sup>)

